

FRAME

Advantages of the screen: tensioned projection surface and unique design of the frame in classic or Velvet finish.

Functionality: any aspect ratio made on request; customization; choice of projection surfaces; frames in the Classic or Velvet standards; easy installation; stability and durability.

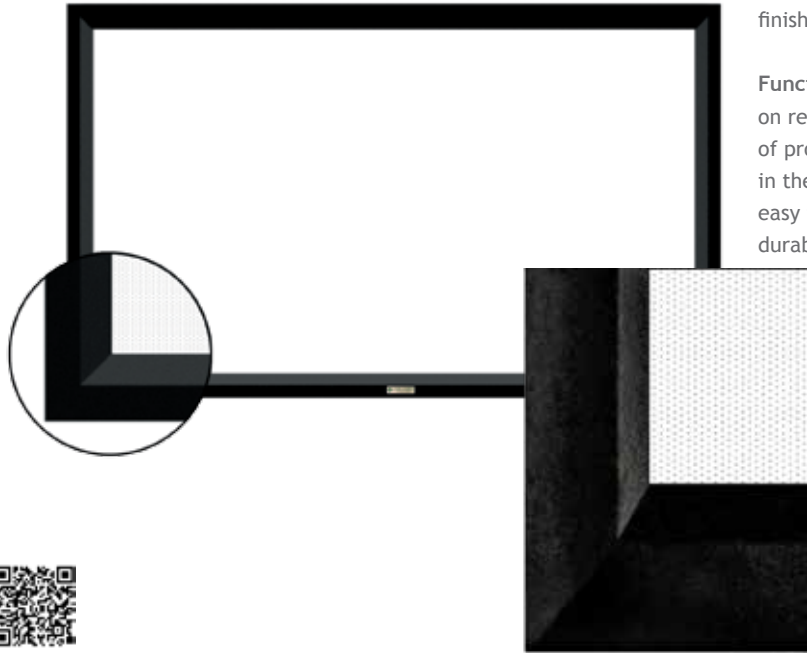

Elegant frame screens for fixed AV installations in professional Home Theatres. Available in any aspect ratio and in a Velvet or Classic frame. Chosen by demanding users for elegant interiors.

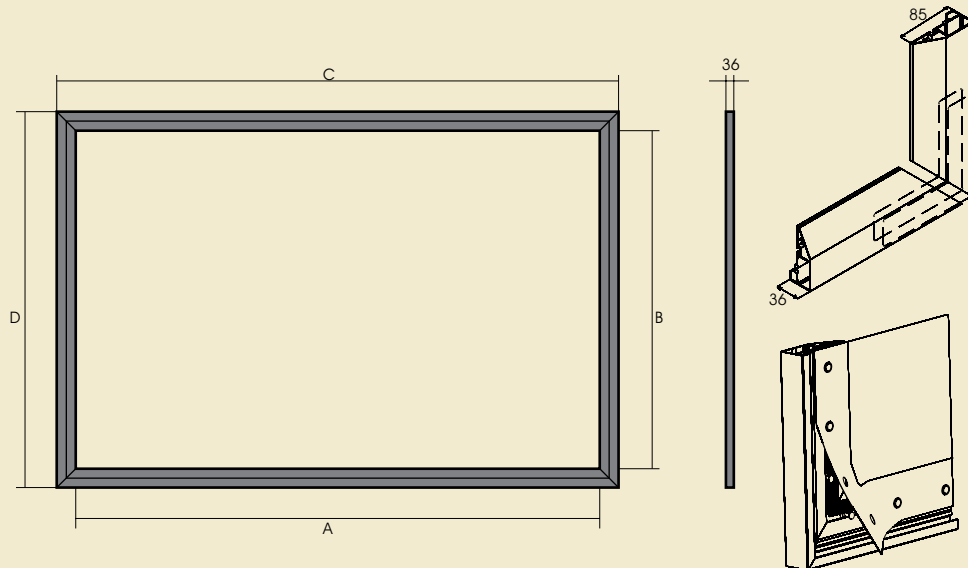

Width (mm)	4:3				16:9			
	A	B	C	D	A	B	C	D
FRAME 180	1800	1350	1970	1520	1800	1013	1970	1183
FRAME 200	2000	1500	2170	1670	2000	1125	2170	1295
FRAME 240	2400	1800	2570	1970	2400	1350	2570	1520
FRAME 260	2600	1950	2770	2120	2600	1463	2770	1633
FRAME 280	2800	2100	2970	2270	2800	1575	2970	1745
FRAME 300	3000	2250	3170	2420	3000	1688	3170	1858
FRAME 350	3500	2625	3670	2795	3500	1969	3670	2139
FRAME 380	3800	2850	3970	3020	3800	2138	3970	2308
FRAME 400	4000	3000	4170	3170	4000	2250	4170	2420

Screen FRAME	
Frame	aluminium (tension of surface system)
Frame colour	<ul style="list-style-type: none"> • black powder coated • black velvet
Installation	• wall
P. surfaces:	<ul style="list-style-type: none"> • Matt White • Dual Grey • Perforated MW
Image aspect ratio	<ul style="list-style-type: none"> • 4:3 • 16:9 • 16:10 • and more
Max. Width of base [cm]	600
Set	<ul style="list-style-type: none"> • elements of frame; • surface; • mounting instruction manual; • assembly kit; • montage elements
Warranty	2 years
Producer	VIZ-ART Automation Europe