

# SCREEN-LIFT

Lift for screens

VIZ-ART  
AUTOMATION

- List of components:
- Mount
  - Installation manual
  - Mounting set



## 1. INSTALLATION:

A. Remove a cover from element A.

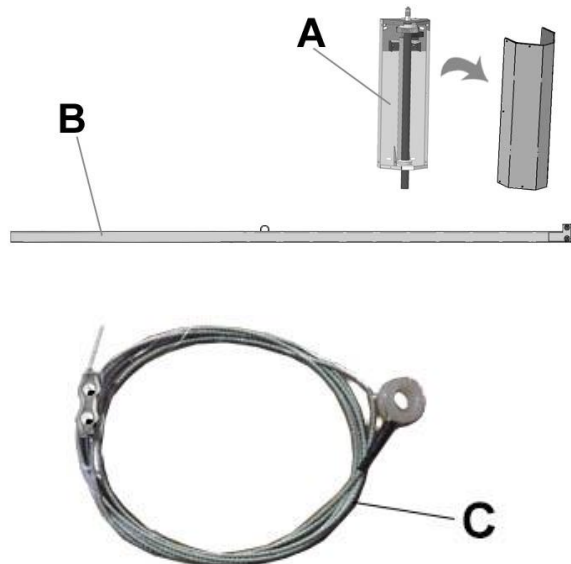

B. Choose a place for installation of lift. Mark installation points for mounting pins. Install element A to concrete Wall using mounting pins and selected screws from mounting set. Precisely level element A (mounting holes lets you to adjust proper position).

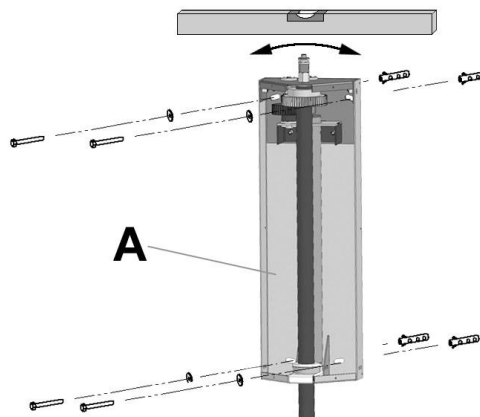

C. Install element B to already mounted element A using 2 screws M8x50.

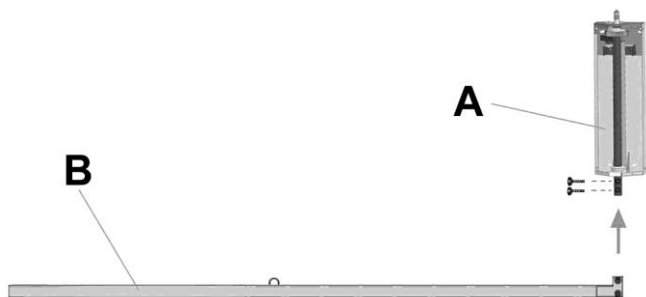

D. Steel cable C (attached to element B) attach to element A – put on a shaft D and screw the screw E M6x10.

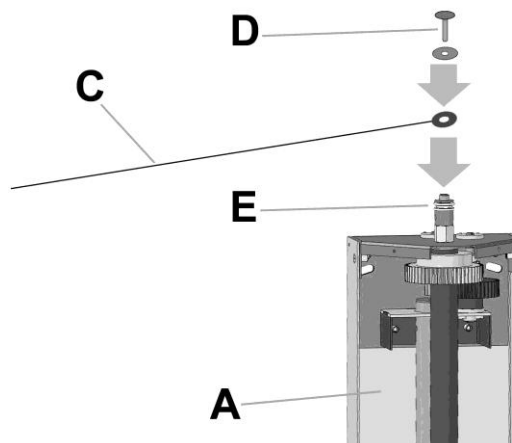

E. Adjust the position: using holes F in motor section, adjust limit switchers using plastic tool-key (in mounting set). Scheme of adjustment is (PRAWO – RIGHT +/- and LEWO –LEFT +/-)

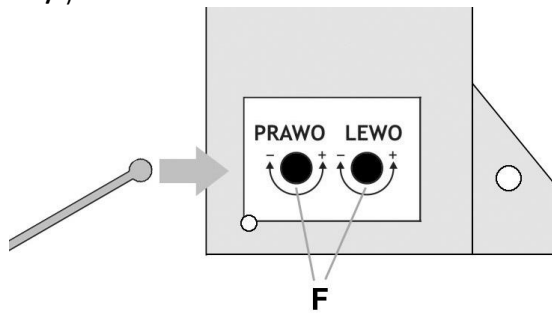

F. connect power supply cable to remote control.

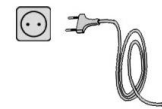

Close a cover of element A, Rusing screws.

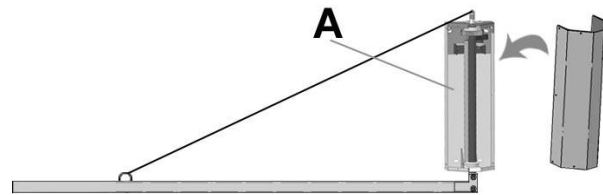

G. Adjust with clamp (H) length of Steel cable in that way, to leave arm (B) in proper horizontal position.

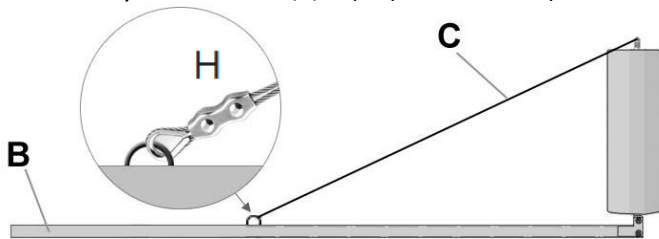

H. Mount projection screen using components G. Components G are optimised to projection screens made by VIZ-ART.

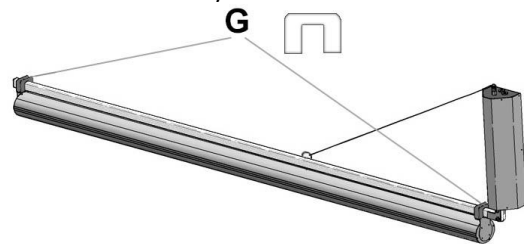

## 2. ELECTRICAL CONNECTIONS:

A.

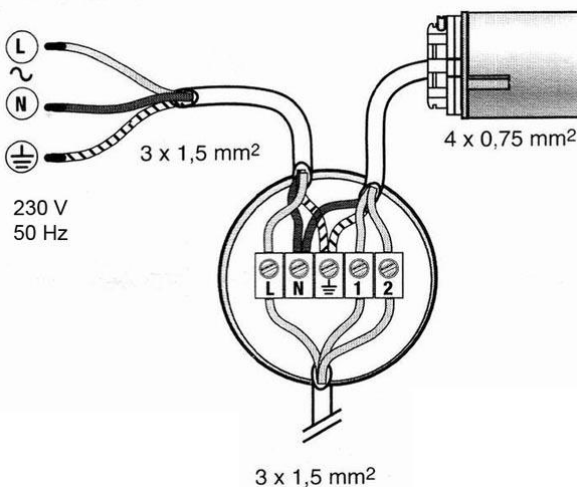

B. **ATTENTION!** ELECTRICAL CONNECTIONS should be done by trained person according to safety rules and standards.

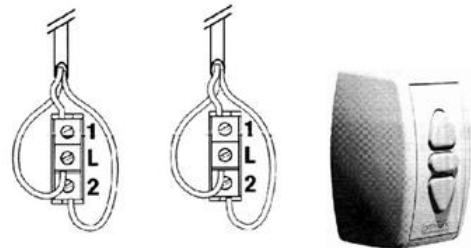

ZACISK	CURRENT DESIGNATION	CABLE FROM THE DRIVE
L	PHASE - L	
N	ZERO - N	BLUE
⊕	EARTH -	YELLOW / GREEN
1	UP DIRECTION	BLACK
2	DOWN DIRECTION	BROWN

## 3. TECHNICAL DATA:

Own weight:	8 - 12 kg
Rotation angle	270°
Capacity:	25 kg

## 4. Inside Mounting Set:

Screws:	M8x50 – 2 szt.      M6x10 – 1 szt. M6x20 – 6 szt.
Pads:	∅6x18 – 1 szt.      ∅8x16 – 2 szt. ∅6x12 – 6 szt.
Nuts:	M8 – 2 szt.      M6 – 4 szt.
Dowels with screws:	∅10x50 – 4 szt.
<ul style="list-style-type: none"> <li>• Wall switch</li> <li>• Steel cable ∅2 set (C)</li> </ul>	<ul style="list-style-type: none"> <li>• Allen key (plastic) 4mm:</li> <li>• screen mounting elements – 2 szt. (G)</li> </ul>

Manufacturer: VIZ-ART Automation  
tel.+48 22/6138899 [www.viz-art.eu](http://www.viz-art.eu)

## Rules of safe operation of VIZ-ART AUTOMATION equipment.

### SAFETY INFORMATION CAUTION

To ensure safety of the personnel, make sure to follow the guidelines provided in this instruction manual. Keep the instruction manual for future reference.

- Do not allow children to play with the device controller (switch or remote control).
- Do not leave device controllers within the reach of children.
- Inspect the equipment assembly periodically to identify and repair any damages.
- If any damages are identified, do not use the equipment until the necessary repairs are made.
- Keep appropriate distance from the equipment during operation. In case of a failure, the equipment may constitute a risk of injury or wounds.
- Do not install any items other than those specified in the equipment instruction manual. All installation and mounting works should be done by an engineer with appropriate licenses.
- Inappropriate mounting may damage the product or cause injury.
- Use only elements compliant with the mounting instructions.
- It is prohibited to perform any steps that may damage the power supply cord or plug.
- Do not modify the power cord, i.e. do not make any structural modifications, do not place the cord in immediate vicinity of hot objects, do not bend or twist the cord, do not pull the cord, do not place any heavy objects on the cord, and do not coil the power cord.
- Using the equipment with a damaged power cord may cause electrocution or shorting of the circuits and fire.
- Do not touch the power cord or plug with wet hands.
- Always follow the guidelines provided in this instruction manual and in the equipment mounting instructions.
- Before installing the equipment, make sure it is complete, free of defects, compliant with your order, and has not sustained damage in transport.

### INSTALLATION GUIDELINES

- The equipment should be installed by a qualified engineer, in accordance with the guidelines provided in the mounting instructions. Electrical connections should be made by a specialist with an appropriate license.
- Install the equipment using screws and mounting elements appropriate for the conditions of the installation, to which the lift is mounted, and stable, original auxiliary elements, dedicated for the specific lift model.
- After mounting the equipment, before first use, check if it is mounted as per the instructions, and level. If the equipment is not level, adjust the mounting. Do not use equipment that is not properly installed.
- Do not modify or unscrew elements of the equipment, as this may cause a risk of permanent damage to the equipment and/or the safety of the users.

### WARRANTY CONDITIONS

The warranty period for the device is 24 months from the date of purchase indicated on the original receipt.

- 1) The warranty period for the device's electric drive is 60 months.
- 2) The warrantor commits to fix free of charge damage suffered by a device delivered to the service point that demonstrates defects resulting from defects in workmanship or materials, which become noticeable during the warranty period.
- 3) The warranty does not cover:
  - a) damage caused by use of the device in a manner other than that described in the user manual,
  - b) damage caused by improper storage or transport,
  - c) mechanical damage,
  - d) abrupt changes in electrical grid voltage,
  - e) disassembly and reassembly,
- 4) Defects will be removed within 14 days from the date the device is accepted on warranty at a service point.
- 5) Service point address



Manufactured after 13.08.2005.

Do not dispose of used electrical and electronic equipment together with municipal waste, due to the presence of substances hazardous to the environment in the equipment. Such devices should be delivered to a collection point for recycling. Information on collection points is available from local government authorities or in stores.



## DECLARATION OF CONFORMITY

### VIZ-ART AUTOMATION



I hereby declare, with sole responsibility, that the products:

**Screen Lifts : Sacro-screen; Screen-Lift, Up-Screen**

to which this declaration relates, in accordance with:

- the Low Voltage Directive 73/23EEC together with the modifications of Directive 93/68/EEC
- EMC Directive 89/336/EEC along with its amendments 92/31/EEC, 93/68/EEC i 91/263/EEC

comply with the following European standards:

**EN 60335-2-97 with reference to EN 60335-1**

**EN 55014-1, EN 55014-2, EN 61000-3-2, EN 61000-3-3**

and are CE certified.

