

# ELLIPSE

Electric projection screen



**LIST OF ITEMS:**

- Electric screen In the casing,
- Mounting elements – 2 pcs.,
- Button switch,
- Assembly kit,
- Installation manual,



**1. INSTALLATION:**

A. In a set installation location (solid ceiling/wall) designate and level points for installation holes. Verify the required distances in the size table.

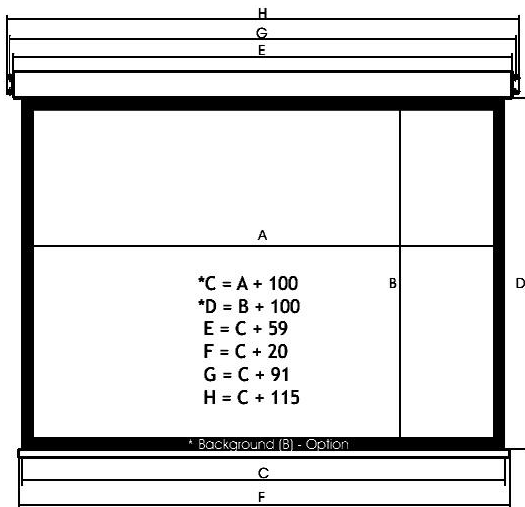

Width (cm)	Size (mm)					
	4:3		16:9		16:10	
	C	D	C	D	C	D
ELLIPSE 180	1800	1350	1800	1020	1800	1130
ELLIPSE 200	2000	1500	2000	1130	2000	1250
ELLIPSE 220	2200	1650	2200	1240	2200	1380
ELLIPSE 240	2400	1800	2400	1350	2400	1500
ELLIPSE 260	2600	1950	2600	1470	2600	1630
ELLIPSE 280	2800	2100	2800	1580	2800	1750
ELLIPSE 300	3000	2250	3000	1690	3000	1880
ELLIPSE 350	3500	2630	3500	1970	3500	2190
ELLIPSE 380	3800	2850	3800	2140	3800	2380
ELLIPSE 400	4000	3000	4000	2250	4000	2500

B. Install mounting elements (A) using wall plugs and screws included in the mounting kit. Please note! When installing onto a plasterboard surface, use special plugs and screws.

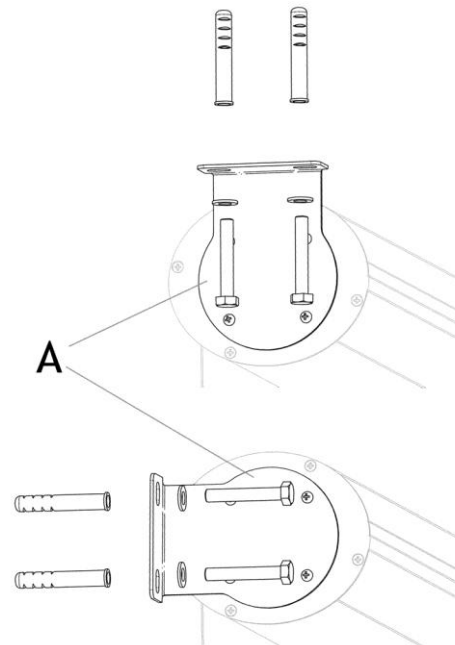

C. **PLEASE NOTE!** Installer decides, which wall plugs and screws are appropriate for the basis.

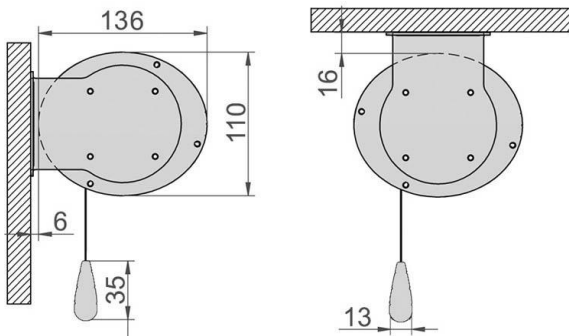

D. When screwing in the projection screen to installed mounting elements A, use screws B included in the mounting kit (with 4 screws on each side of the screen). **PLEASE NOTE!** When installing the screen, make sure that the embossed VIZ-ART logo is directed towards the viewer and visible on the left side of the screen. Only this installation position is correct.

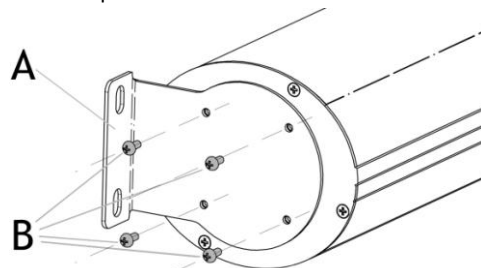

## 2. ELECTRICAL CONNECTION:

A.

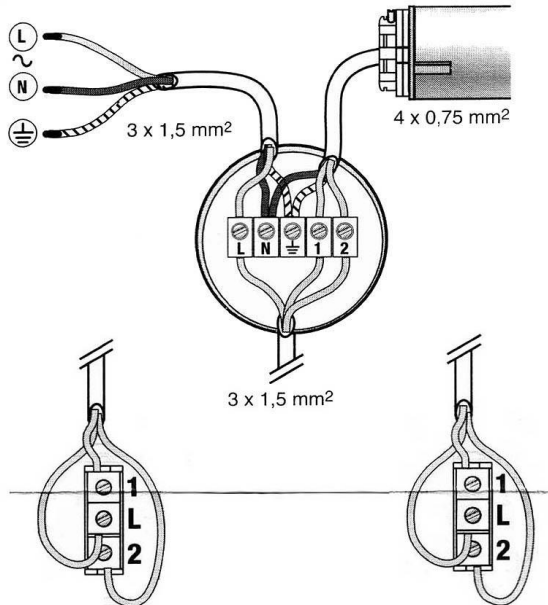

ZACISK	CURRENT DESIGNATION	CABLE FROM THE DRIVE
L	PHASE - L	
N	ZERO - N	BLUE
⊕	EARTH -	YELLOW / GREEN
1	UP DIRECTION	BLACK
2	DOWN DIRECTION	BROWN

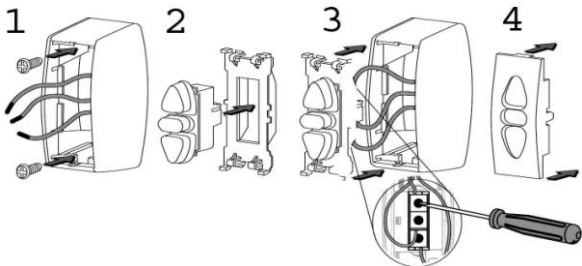

B. Electrical connection diagram for a screen with the radio control option built-in engine.

**PLEASE NOTE!** The electrical connection should be performed by a person with appropriate certification and in accordance with health and safety regulations.

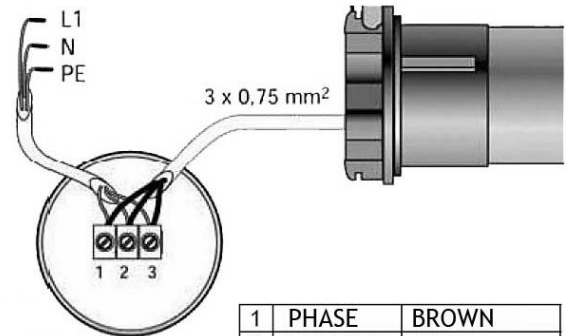

230V - 50 Hz  
3 x 1,5 mm²

1	PHASE	BROWN
2	NEUTRAL	BLUE
3	EARTH	YELLOW-GREEN*

C. SAFETY in transport and during installation:

**Keep and do not disassemble the bottom bar from the screen until the end of the installation.** Removal of the protection before finishing the installation can cause the bar to fall into a housing of a screen and damage the projection surface. Before each transportation make sure that the bar of the screen is protected from falling into a housing.

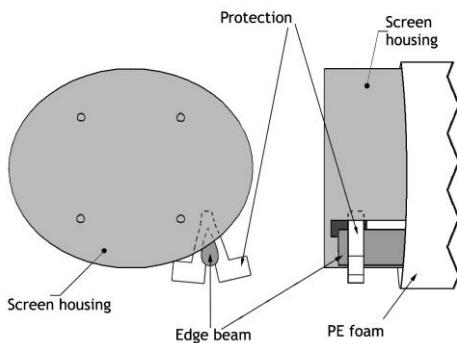

D. Optional control:

The electric screen can be upgraded with wireless radio (RC) or infrared (IR) controllers.

When programming the stop positions, use the programming manual.

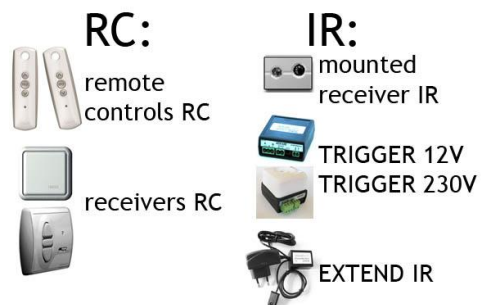

## 4. TECHNICAL DATA:

Image aspect ratio:

4:3    16:9    16:10    other

Regulation: Only authorized installers can change ends positions of screen. It threatens breaking of projection surface.

Power supply:

230V / 50 HZ , 220V / 60 HZ

Manufacturer: VIZ-ART Automation  
tel.+48 22/6138899    www.viz-art.eu

## Rules of safe operation of VIZ-ART AUTOMATION equipment.

### SAFETY INFORMATION CAUTION

To ensure safety of the personnel, make sure to follow the guidelines provided in this instruction manual. Keep the instruction manual for future reference.

- Do not allow children to play with the device controller (switch or remote control).
- Do not leave device controllers within the reach of children.
- Inspect the equipment assembly periodically to identify and repair any damages.
- If any damages are identified, do not use the equipment until the necessary repairs are made.
- Keep appropriate distance from the equipment during operation. In case of a failure, the equipment may constitute a risk of injury or wounds.
- Do not install any items other than those specified in the equipment instruction manual. All installation and mounting works should be done by an engineer with appropriate licenses.
- Inappropriate mounting may damage the product or cause injury.
- Use only elements compliant with the mounting instructions.
- It is prohibited to perform any steps that may damage the power supply cord or plug.
- Do not modify the power cord, i.e. do not make any structural modifications, do not place the cord in immediate vicinity of hot objects, do not bend or twist the cord, do not pull the cord, do not place any heavy objects on the cord, and do not coil the power cord.
- Using the equipment with a damaged power cord may cause electrocution or shorting of the circuits and fire.
- Do not touch the power cord or plug with wet hands.
- Always follow the guidelines provided in this instruction manual and in the equipment mounting instructions.
- Before installing the equipment, make sure it is complete, free of defects, compliant with your order, and has not sustained damage in transport.

### INSTALLATION GUIDELINES

- The equipment should be installed by a qualified engineer, in accordance with the guidelines provided in the mounting instructions. Electrical connections should be made by a specialist with an appropriate license.
- Install the equipment using screws and mounting elements appropriate for the conditions of the installation, to which the lift is mounted, and stable, original auxiliary elements, dedicated for the specific lift model.
- After mounting the equipment, before first use, check if it is mounted as per the instructions, and level. If the equipment is not level, adjust the mounting. Do not use equipment that is not properly installed.
- Do not modify or unscrew elements of the equipment, as this may cause a risk of permanent damage to the equipment and/or the safety of the users.

### WARRANTY CONDITIONS

The warranty period for the device is 24 months from the date of purchase indicated on the original receipt.

- 1) The warranty period for the device's electric drive is 60 months.
  - 2) The warrantor commits to fix free of charge damage suffered by a device de-livered to the service point that demonstrates defects resulting from defects in workmanship or materials, which become noticeable during the warranty pe-riod.
- 3) The warranty does not cover:
  - a) damage caused by use of the device in a manner other than that described in the user manual,
  - b) damage caused by improper storage or transport,
  - c) mechanical damage,
  - d) abrupt changes in electrical grid voltage,
  - e) disassembly and reassembly,
- 4) Defects will be removed within 14 days from the date the device is accepted on warranty at a service point.
- 5) Service point address



Manufactured after 13.08.2005.

Do not dispose of used electrical and electronic equipment together with municipal waste, due to the presence of substances hazardous to the environment in the equipment. Such devices should be delivered to a collection point for recycling. Information on collection points is available from local government authorities or in stores.



## DECLARATION OF CONFORMITY

VIZ-ART AUTOMATION



I hereby declare, with sole responsibility, that the products:

**Electric screens:** SUPER NOVA, SUPER NOVA TENSION, MASKED, MASKED TENSION, ELLIPSE, ELLIPSE TENSION, BUSINESS Plus,

to which this declaration relates, in accordance with:

- the Low Voltage Directive 73/23EEC together with the modifications of Directive 93/68/EEC
- EMC Directive 89/336/EEC along with its amendments 92/31/EEC, 93/68/EEC i 91/263/EEC

comply with the following European standards:

**EN 60335-2-97 with reference to EN 60335-1**

**EN 55014-1, EN 55014-2, EN 61000-3-2, EN 61000-3-3**

and are CE certified.

