

V-LIFT/ VMAX-LIFT 95

new control

TV lifts



LIST OF COMPONENTS::

- Lift
- Cable guide
- Mounting brackets for TV
- Wall switch
- Mounting set
- Instruction manual



1. INSTALLATION – Option 1:

Installation of the V-LIFT / VMAX-LIFT together with TV inside of a piece of furniture selected by the user. Universal V-lifts is designed to a base cabinet. A sliding TV swings the top element of the furniture (not included). While hiding plasma the lift causes swinging elements of the top. This way of installation requires hinges in the top of the furniture.

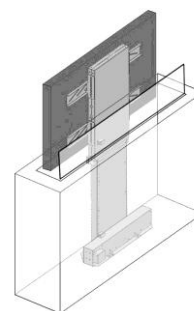

- A. Choose the lift installation place. Mark a place for holes and screw on using screws A.

Attention! The installation is to be run only when the power is off and the lift is down to its maximum.

A V-lift / VMAX-lift is to be installed to a stable piece of furniture using 4 screws. Level up the lift in order to improve safety.

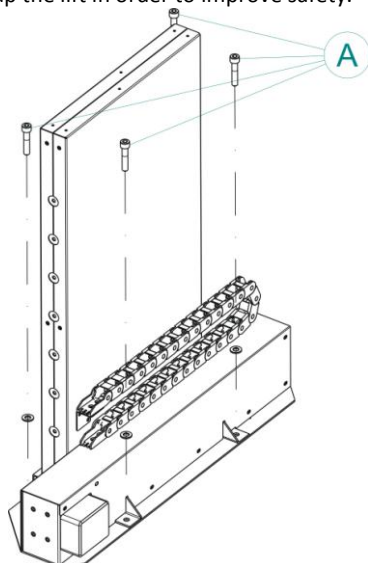

Move the lift to max height position, then install TV unit with needed mounting accessories.

- B. Attach elements B to a plasma TV/LCD using screws number 1 and 2 (from mounting set).

Installation to a plasma TV

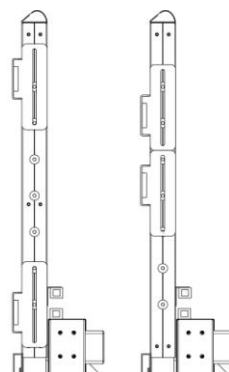
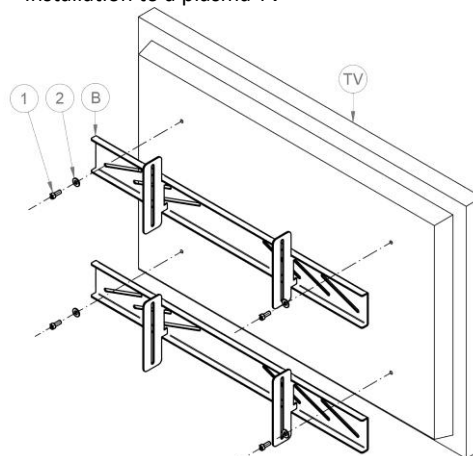

Range of spacing brackets – check in the catalogue card selected lift model

C. Attach repealing elements C to the lift.

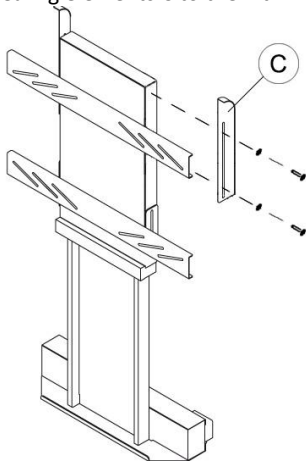

D. Installed lift (w plasma TV) slid out and hidden.

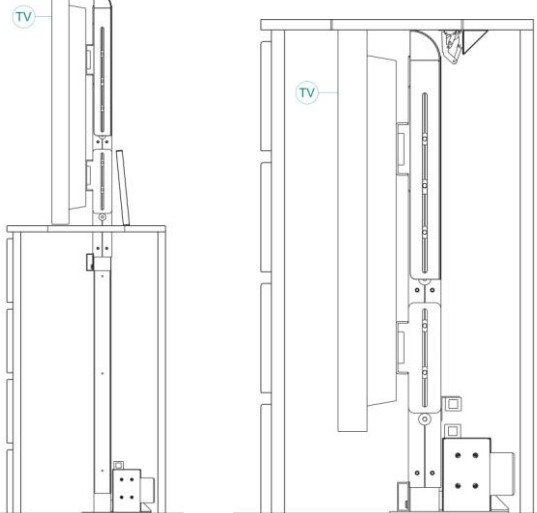

2. INSTALLATION - OPTION 2:

TV is to be installed inside a piece of furniture using V-LIFT / VMAX-LIFT. In such installation elements of the top are permanently attached above a plasma TV/LCD (additional option). Sliding a TV out of furniture raises the top of the furniture.

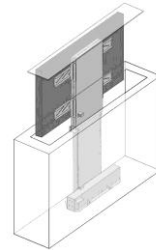

A. Choose the lift installation place. Mark a place for holes and screw on using screws A.

Attention! The installation is to be run only when the power is off and the lift is down to its maximum.

A V-LIFT / VMAX-LIFT is to be installed to a stable piece of furniture using four screws.

Level up the lift in order to improve safety.

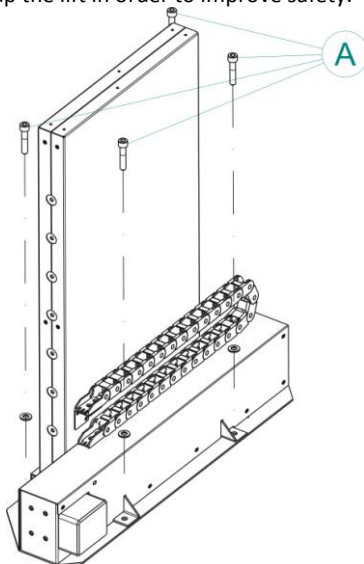

Slide the lift up to the maximum and attach TV to the lifts all together with installed fastening elements.

B. Install elements C and D to TV using screws 1 and 2 (from mounting set)

Installation Plasma TV

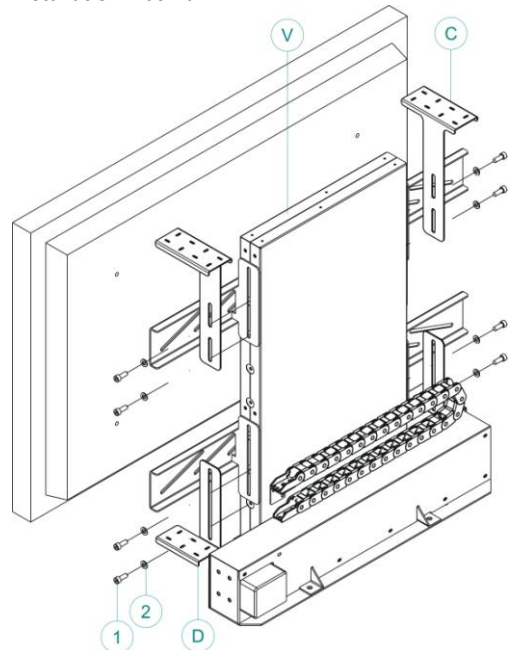

C. Installed lift (with a plasma TV) slid out and hidden.

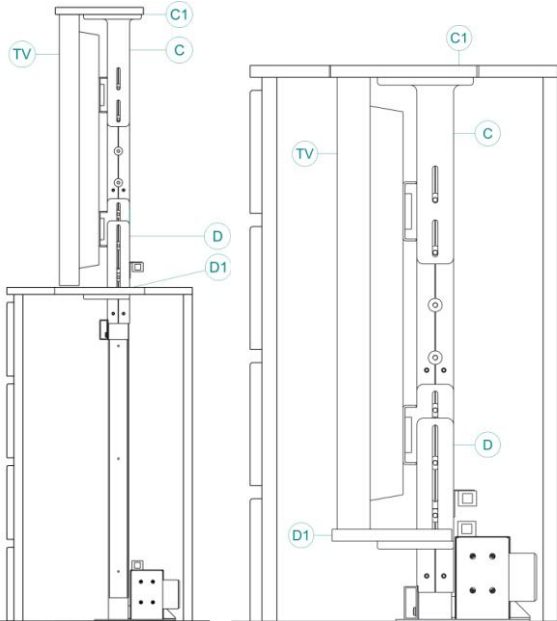

3. Connection scheme:

Option - A plasma TV located Inside a ceiling housing or a false ceiling.
A TV slides out on the V-LIFT / VMAX-LIFT.

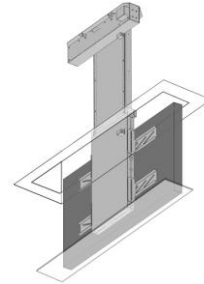

- A. Choose the lift installation place. Mark a place for holes and skrew on using screws A.

Attention! The installation is to be run only when the power is off and the lift is down to its maximum.

A V-lift / VMAX-lift is to be installed to a stable piece of ceiling using 4 screws.
Level up the lift in order to improve safety.

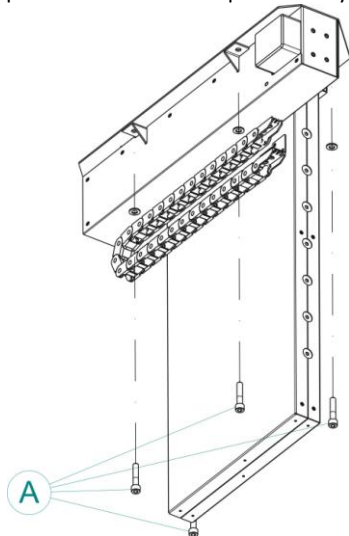

Move the lift to max height position, then install TV unit with needed mounting accesories.

- B. Attach elements C (optional) to a plasma/LCD TV using screws number 1 and 2 (from mounting set).

Installation to a plasma TV

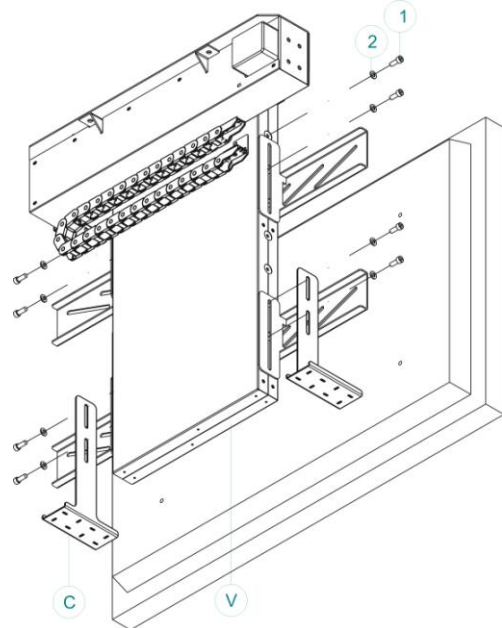

IMPORTANT: Elements C ordered optional.

4. ELECTRICAL CONNECTION:

Only persons with appropriate authorization may connect the lift to a 230V power supply. The connection must follow the diagram and the instructions.

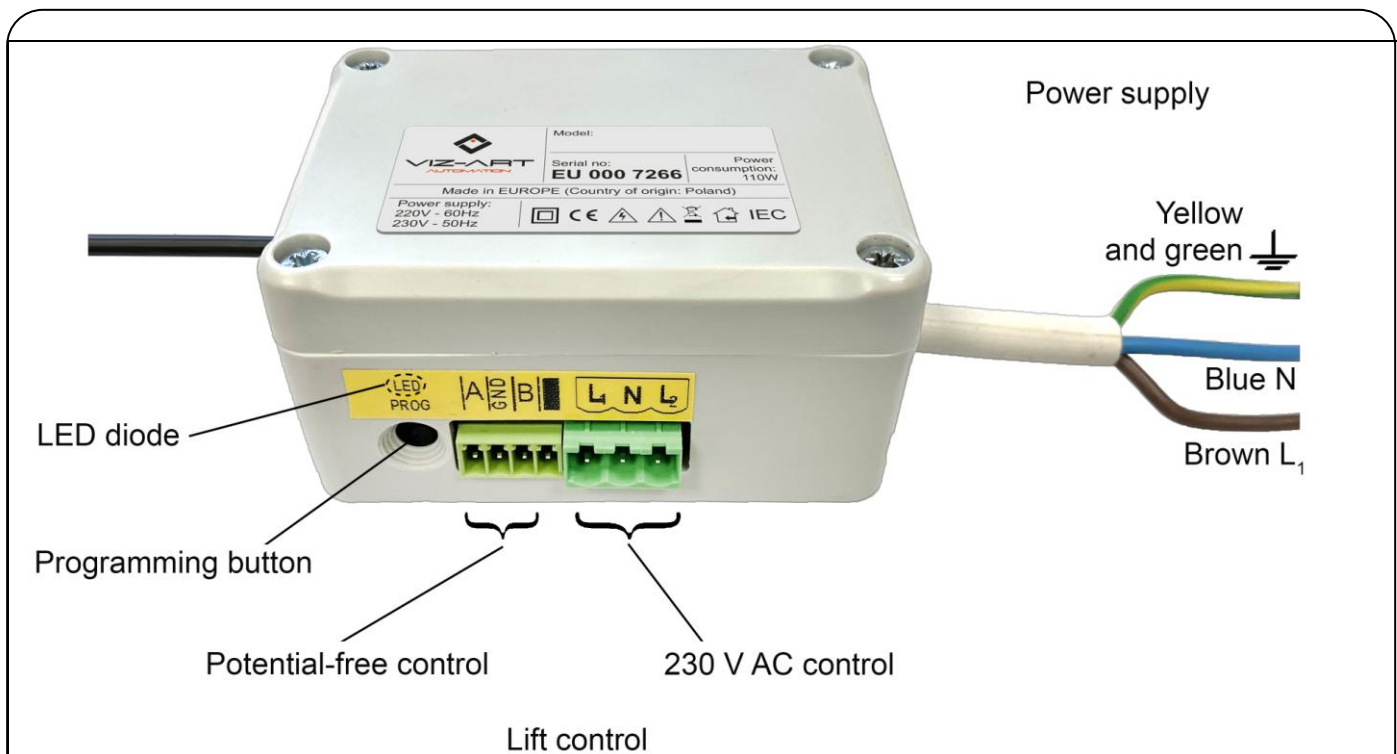

5. Preparing for programming & programming mode:

1. After V-LIFT / VMAX-LIFT is installed in furniture, connect the push-button switch to the wire (POTENTIAL FREE CONTROL).
2. Using attached connection scheme, connect V-LIFT / VMAX-LIFT lift, LED diode will flash 20 times. After that system is ready to be programmed
3. Install your LCD TV / monitor on a lift. Programming mode can be run when V-LIFT / VMAX-LIFT is loaded with your display (Symmetrically installed on a V-LIFT / VMAX-LIFT lift).

„UP” and „DOWN” position programming:

1. touch (firm touch) with your finger desired „touch area” (icon) and hold until LED diode flashes 5 times. Release your finger . LED diode will flash 20 times, confirming start programming mode.
2. **„DOWN” position programming:** Set your V-LIFT / VMAX-LIFT lift on expected down position, using push-button switch, then touch (firm touch) with your finger desired „touch area” (icon) to confirm down position of lift. LED diode will flash quickly 4 times confirming this setup.
3. **„UP” position programming:** Set your V-LIFT / VMAX-LIFT lift on expected up position, using push-button switch, then touch (firm touch) with your finger desired „touch area” (icon) to confirm up position of lift. LED diode will flash 20 times to confirming up position of lift and closing programming mode.
4. **End of programming:** V-LIFT / VMAX-LIFT lift is programmed and ready to use.

Attention: After V-LIFT / VMAX-LIFT lif, it is possible to control it using push-button switch POTENTIAL FREE CONTROL or VOLTAGE CONTROL.

6. TECHNICAL DATA: a: V-LIFT; b: VMAX-LIFT 95

Range of TV models:	a: 26" do 46"; b: do 95"
Silent operation:	42dB
Height of the mechanism:	a: 783mm; b: 856mm
Max. reach:	a: 710mm; b: 1400mm
Stop positions:	Regulationed – programmed
Mounting location:	furnitures, ceiling, floor
Power consumption:	40 W
Lift capacity:	a: to 70 kg; b: 130kg
Control:	<ul style="list-style-type: none"> • RS-232 • Switch key • TRIGGER 12V • RF • IR
Power Supply:	230 V / direct current

Manufacturer: VIZ-ART Automation
tel.+48 22/6138899 www.viz-art.eu

Rules of safe operation of VIZ-ART AUTOMATION equipment.

SAFETY INFORMATION CAUTION

To ensure safety of the personnel, make sure to follow the guidelines provided in this instruction manual. Keep the instruction manual for future reference.

- Do not allow children to play with the device controller (switch or remote control).
- Do not leave device controllers within the reach of children.
- Inspect the equipment assembly periodically to identify and repair any damages.
- If any damages are identified, do not use the equipment until the necessary repairs are made.
- Keep appropriate distance from the equipment during operation. In case of a failure, the equipment may constitute a risk of injury or wounds.
- Do not install any items other than those specified in the equipment instruction manual. All installation and mounting works should be done by an engineer with appropriate licenses.
- Inappropriate mounting may damage the product or cause injury.
- Use only elements compliant with the mounting instructions.
- It is prohibited to perform any steps that may damage the power supply cord or plug.
- Do not modify the power cord, i.e. do not make any structural modifications, do not place the cord in immediate vicinity of hot objects, do not bend or twist the cord, do not pull the cord, do not place any heavy objects on the cord, and do not coil the power cord.
- Using the equipment with a damaged power cord may cause electrocution or shorting of the circuits and fire.
- Do not touch the power cord or plug with wet hands.
- Always follow the guidelines provided in this instruction manual and in the equipment mounting instructions.
- Before installing the equipment, make sure it is complete, free of defects, compliant with your order, and has not sustained damage in transport.

INSTALLATION GUIDELINES

- The equipment should be installed by a qualified engineer, in accordance with the guidelines provided in the mounting instructions. Electrical connections should be made by a specialist with an appropriate license.
- Install the equipment using screws and mounting elements appropriate for the conditions of the installation, to which the lift is mounted, and stable, original auxiliary elements, dedicated for the specific lift model.
- After mounting the equipment, before first use, check if it is mounted as per the instructions, and level. If the equipment is not level, adjust the mounting. Do not use equipment that is not properly installed.
- Do not modify or unscrew elements of the equipment, as this may cause a risk of permanent damage to the equipment and/or the safety of the users.

WARRANTY CONDITIONS

The warranty period for the device is 24 months from the date of purchase indicated on the original receipt.

- 1) The warranty period for the device's electric drive is 60 months.
- 2) The warrantor commits to fix free of charge damage suffered by a device delivered to the service point that demonstrates defects resulting from defects in workmanship or materials, which become noticeable during the warranty period.
- 3) The warranty does not cover:
 - a) damage caused by use of the device in a manner other than that described in the user manual,
 - b) damage caused by improper storage or transport,
 - c) mechanical damage,
 - d) abrupt changes in electrical grid voltage,
 - e) disassembly and reassembly,
- 4) Defects will be removed within 14 days from the date the device is accepted on warranty at a service point.
- 5) Service point address



Manufactured after 13.08.2005.

Do not dispose of used electrical and electronic equipment together with municipal waste, due to the presence of substances hazardous to the environment in the equipment. Such devices should be delivered to a collection point for recycling. Information on collection points is available from local government authorities or in stores.



DECLARATION OF CONFORMITY

VIZ-ART AUTOMATION



I hereby declare, with sole responsibility, that the products:

Lifts: V-LIFT VESA; VMAX - LIFT 95; CP-LIFT S; CP-LIFT M; CP-LIFT L;
ART-LIFT; SIDE LIFT 65; SIDE-LIFT Pro; SMARTBOARD LIFT;
ADVANCED LCD Lift 17; ADVANCED LCD Lift 19; ADVANCED LCD Lift 24

to which this declaration relates, in accordance with:

- the Low Voltage Directive 73/23EEC together with the modifications of Directive 93/68/EEC
- EMC Directive 89/336/EEC along with its amendments 92/31/EEC, 93/68/EEC and 91/263/EEC

comply with the following European standards:

EN 60335-2-97 with reference to EN 60335-1
EN 55014-1, EN 55014-2, EN 61000-3-2, EN 61000-3-3

and are CE certified.

